



ACCESS CODE FOR TRANSMISSION

Attachment G:

Forms

Table of contents

Table of contents	2
G.1. Services Request Forms	34
1.1 G.1a – Services Request Form for Entry at Interconnection Points	34
1.2 G.1b – Services Request Form for Exit at Interconnection Points	45
1.3 G.1c – Services Request Form for Exit at End User Domestic Exit Points	56
1.4 G.1d – Services Request Form for Operational Capacity Usage Commitments	67
1.5 G.1e – Services Request Form for Wheeling Services	78
1.6 G.1f – Services Request Form for Zee Platform Services	89
1.7 G.1g – Services Request Form for Direct Line Services	94
1.8 G.1h – Services Request Form for Cross Border Delivery Services	104
1.9 G.1i – Services Request Form for Fix/Flex Rate Type at End User Domestic Exit Points	12
1.10 G.1j – Services Request Form for Calendar Day Regime at End User Domestic Exit Points	13
1.11 G.1k – Services Request Form for Quality Conversion Services	14
1.12 G.1l – Services Request Form for ZTP Trading Services	15
1.13 G.1m – Services Request Form for Capacity Conversion Service	194
G.2. Services Confirmation Form	204
G.3. Assignment Form	214
G.4. Allocation Agreement	224
G.5. Form of Capacity Pooling Agreement	232
G.6 Grid User Details Form	302
G.7 TSO Details Form	333
G.8. Oversubscription and Buy-Back (CMP)	353
G.8a – Notification of Buy-Back	353
G.8b – Capacity Buy-Back Offer	363
G.8c – Result Capacity Buy-Back Offer	373
G.9 – Surrender of Capacity	383
G.10. Imbalance Pooling Form	393
	393
	18

G.1. Services Request Forms

1.1 G.1a – Services Request Form for Entry at Interconnection Points



Fluxys SA - Commercial Direction
 Avenue des Arts 31 - B-1040 Brussels
 Phone: +32 (0)2 282 77 77 - Fax +32 (0)2 282 02 50
info.transport@fluxys.com

G.1a - Services Request Form

GRID USER :

Company Name:	Date Request:
Contact person:	
Phone:	STA Ref:
Mobile:	
E-mail:	Your Ref:

ENTRY

Interconnection Point	Quantity (kWh/h)	Start date <i>(dd/mm/yyyy)</i>	End date <i>(dd/mm/yyyy)</i>
Interconnection Point	Quantity (kWh/h)	Start date <i>(dd/mm/yyyy)</i>	End date <i>(dd/mm/yyyy)</i>
Interconnection Point	Quantity (kWh/h)	Start date <i>(dd/mm/yyyy)</i>	End date <i>(dd/mm/yyyy)</i>
Interconnection Point	Quantity (kWh/h)	Start date <i>(dd/mm/yyyy)</i>	End date <i>(dd/mm/yyyy)</i>
Interconnection Point	Quantity (kWh/h)	Start date <i>(dd/mm/yyyy)</i>	End date <i>(dd/mm/yyyy)</i>
Interconnection Point	Quantity (kWh/h)	Start date <i>(dd/mm/yyyy)</i>	End date <i>(dd/mm/yyyy)</i>

1.2 G.1b – Services Request Form for Exit at Interconnection Points



Fluxys SA - Commercial Direction
 Avenue des Arts 31 - B-1040 Brussels
 Phone: +32 (0)2 282 77 77 - Fax +32 (0)2 282 02 50
info.transport@fluxys.com

G.1b - Services Request Form

GRID USER :

Company Name: Date Request:
 Contact person: STA Ref:
 Phone: Your Ref:
 Mobile:
 E-mail:

EXIT AT INTERCONNECTION POINT

Interconnection Point	Quantity (kWh/h)	Start date	End date
		(dd/mm/yyyy)	

1.3 G.1c – Services Request Form for Exit at End User Domestic Exit Points



Fluxys SA - Commercial Direction
 Avenue des Arts 31 - B-1040 Brussels
 Phone: +32 (0)2 282 77 77 - Fax +32 (0)2 282 02 50
info.transport@fluxys.com

G.1c - Transportation Request Form

GRID USER :

Company Name:	Date Request:
Contact person:	STA Ref:
Phone:	Your Ref:
Mobile:	
E-mail:	

End-User Domestic Exit Point

NAME END-USER DOMESTIC POINT	GEL REF	Quantity (kWh/h)	Start date (dd/mm/yyyy)	End date

1.4 G.1d – Services Request Form for Operational Capacity Usage Commitments



Fluxys Belgium SA - Commercial Direction
 Avenue des Arts 31 - B-1040 Brussels
 Phone: +32 (0)2 282 77 77 - Fax +32 (0)2 282 02 50
info.transport@fluxys.com

G.1d - Service Request Form

GRID USER :

Company Name: Date Request:
 Contact person:
 Phone: STA Ref:
 Mobile:
 E-mail:

OCUC

Auction IP	Auction Ref	Auction Period		Quantity (kWh/h)	OCUC
		Start date	End date		
Entry	AUC-				
Exit	AUC-				

Auction IP	Auction Ref	Auction Period		Quantity (kWh/h)	OCUC
		Start date	End date		
Entry	AUC-				
Exit	AUC-				

Auction IP	Auction Ref	Auction Period		Quantity (kWh/h)	OCUC
		Start date	End date		
Entry	AUC-				
Exit	AUC-				

Auction IP	Auction Ref	Auction Period		Quantity (kWh/h)	OCUC
		Start date	End date		
Entry	AUC-				
Exit	AUC-				

1.5 G.1e – Services Request Form for Wheeling Services



Fluxys Belgium SA - Commercial Direction
 Avenue des Arts 31 - B-1040 Brussels
 Phone: +32 (0)2 282 77 77 - Fax +32 (0)2 282 02 50
info.transport@fluxys.com

G.1e - Service Request Form

GRID USER :

Company Name: Date Request:
 Contact person:
 Phone: STA Ref:
 Mobile:
 E-mail:

WHEELING

	AUCTION IP	AUCTION REF	AUCTION PERIOD		Quantity (kWh/h)	WHEELING
			Start date	End date		
			(dd/mm/yyyy)			

Entry		AUC-			
Exit		AUC-			

	AUCTION IP	AUCTION REF	AUCTION PERIOD		Quantity (kWh/h)	WHEELING
			Start date	End date		
			(dd/mm/yyyy)			

Entry		AUC-			
Exit		AUC-			

	AUCTION IP	AUCTION REF	AUCTION PERIOD		Quantity (kWh/h)	WHEELING
			Start date	End date		
			(dd/mm/yyyy)			

Entry		AUC-			
Exit		AUC-			

	AUCTION IP	AUCTION REF	AUCTION PERIOD		Quantity (kWh/h)	WHEELING
			Start date	End date		
			(dd/mm/yyyy)			

Entry		AUC-			
Exit		AUC-			

1.6 G.1f – Services Request Form for Zee Platform Services



Fluxys SA - Commercial Direction
 Avenue des Arts 31 - B-1040 Brussels
 Phone: +32 (0)2 282 77 77 - Fax +32 (0)2 282 02 50
info.transport@fluxys.com

G.1f - Services Request Form

GRID USER :

Company Name:	Date Request:
Contact person:	STA Ref:
Phone:	Your Ref:
Mobile:	
E-mail:	

ZEE PLATFORM

	Points	Start date (dd/mm/yyyy)
1		
2		
3		
4		

1.7 G.1g – Services Request Form for Direct Line Services



G.1g - Transportation Request Form

GRID USER :

Company Name: Date Request:
 Contact person: STA Ref:
 Phone:
 Mobile:
 E-mail:

DIRECT LINE

DIRECT LINE	Quantity (kWh/h)	Start date (dd/m.m/yyyy)	End date
DIRECT LINE	Quantity (kWh/h)	Start date (dd/m.m/yyyy)	End date
DIRECT LINE	Quantity (kWh/h)	Start date (dd/m.m/yyyy)	End date
DIRECT LINE	Quantity (kWh/h)	Start date (dd/m.m/yyyy)	End date
DIRECT LINE	Quantity (kWh/h)	Start date (dd/m.m/yyyy)	End date

1.8 G.1h– Services Request Form for Cross Border Delivery Services



Fluxys Belgium SA - Commercial Direction
 Avenue des Arts 31 - B-1040 Brussels
 Phone: +32 (0)2 282 77 77 - Fax +32 (0)2 282 02 50
info.transport@fluxys.com

G.1h - Services Request Form

GRID USER :

Company Name: Date Request:
 Contact person: STA Ref:
 Phone:
 Mobile:
 E-mail:

Entry and associated Corss Border Delivery Service

Interconnection Point	Quantity (kWh/h)	Start date	End date
		(dd/mm/yyyy)	
Dunkirk LNG Terminal (DKB) Entry			

OCUC and associated Corss Border Delivery Service

OCUC	Quantity (kWh/h)	Start date	End date
		(dd/mm/yyyy)	
OCUC Dunkirk LNG Terminal - Zeebrugge Beach			



Fluxys Belgium SA - Commercial Direction
 Avenue des Arts 31 - B-1040 Brussels
 Phone: +32 (0)2 282 77 77 - Fax +32 (0)2 282 02 50
info.transport@fluxys.com

G.1h - Services Request Form

GRID USER :

Company Name: Date Request:
 Contact person: STA Ref:
 Phone:
 Mobile:
 E-mail:

Entry and associated Cross Border Delivery Service

Interconnection Point	Quantity (kWh/h)	Start date	End date
		(dd/mm/yyyy)	
Dunkirk LNG Terminal (DKB) Entry			

OCUC and associated Cross Border Delivery Service

OCUC	Quantity (kWh/h)	Start date	End date
		(dd/mm/yyyy)	
OCUC Dunkirk LNG Terminal - Zeebrugge			

1.9 G.1i – Services Request Form for Fix/Flex Rate Type at End User Domestic Exit Points



G.1i - Services Request Form

GRID USER :

<p>Company Name: ▶</p> <p>Contact person: ▶</p> <p>Phone: ▶</p> <p>Mobile: ▶</p> <p>E-mail: ▶</p>	<p>Date Request: ▶</p> <p>STA Ref: ▶</p>
--	--

End-User Domestic Exit Point

END-USER DOMESTIC POINT	Quantity (kWh/h)	Start date (dd/m/yyyy)	# calendar years	Fix Flex Rate Type
				└┘
				└┘
				└┘
				└┘
				└┘

* Note that the Fix/Flex Rate Type can only be attributed if all Grid Users active on the same End User Domestic Exit Point XP request the Fix/Flex Rate Type for the considered calendar year

1.10 G.1j – Services Request Form for Calendar Day Regime at End User Domestic Exit Points



G.1j - Services Request Form

GRID USER :

Company Name:	✓	Date Request:	✓
Contact person:	✓	STA Ref:	✓
Phone:	✓			
Mobile:	✓			
E-mail:	✓			

End-User Domestic Exit Point

END-USER DOMESTIC POINT	Start date (dd/mm/yyyy)	# Calendar years	Calendar Day Regime
			┌┐
			┌┐
			┌┐
			┌┐
			┌┐

* Note that the Calendar Day Regime can only be attributed if all Grid Users active on the same End User Domestic Exit Point request the Calendar Day Regime for the considered calendar year

1.11 G.1k – Services Request Form for Quality Conversion Services



Fluxys Belgium SA - Commercial Direction
 Avenue des Arts 31 - B-1040 Brussels
 Phone: +32 (0)2 282 77 77 - Fax +32 (0)2 282 02 50
info.transport@fluxys.com

G.1k - Services Request Form

GRID USER :

Company Name: Date Request:
 Contact person: STA Ref:
 Phone:
 Mobile:
 E-mail:

Peak Load Quality Conversion bundles H -> L

Requested number of Standard Bundled Units (SBU's)	Start date	End date
	(dd/mm/yyyy)	

Base Load Quality Conversion Service H -> L

Quantity(kWh/h)	Start date	End date
	(dd/mm/yyyy)	

Seasonal Load Quality Conversion Service H -> L

Quantity(kWh/h)	Start date	End date
	(dd/mm/yyyy)	

Quality Conversion Service L -> H

Quantity(kWh/h)	Start date	End date
	(dd/mm/yyyy)	

1.12 G.11 – Services Request Form for ZTP TradingHub Services



Fluxys Belgium SA - Commercial Direction
 Avenue des Arts 31 - B-1040 Brussels
 Phone: +32 (0)2 282 77 77 - Fax +32 (0)2 282 02 50
info.transport@fluxys.com

G.11 - Service Request Form

GRID USER :

Company Name: Date Request:
 Contact person: STA Ref:
 Phone:
 Mobile:
 E-mail:

Hub Services

Hub Services requested	Yes/no	Start Date(*)
		(dd/mm/yyyy)
ZTP Physical Trading Services		
ZTP Notional Trading Services		
ZTPL Notional Trading Services		

(*) The services are subscribed for an unlimited duration, as of Start Date



Fluxys Belgium SA - Commercial Direction
 Avenue des Arts 31 - B-1040 Brussels
 Phone: +32 (0)2 282 77 77 - Fax +32 (0)2 282 02 50
info.transport@fluxys.com

G.11 - Service Request Form

GRID USER :

Company Name: Date Request:
 Contact person: STA Ref:
 Phone:
 Mobile:
 E-mail:

ZTP Trading Services

ZTP Trading Services	Yes/no	Start Date(*) (dd/mm/yyyy)
ZTP Physical Trading Services		
ZTP Notional Trading Services		
ZTPL Notional Trading Services		

(*) The services are subscribed for an unlimited duration, as of Start Date



Fluxys Belgium SA - Commercial Direction
 Avenue des Arts 31 - B-1040 Brussels
 Phone: +32 (0)2 282 77 77 - Fax +32 (0)2 282 02 50
info.transport@fluxys.com

G.11 - Service Request Form

GRID USER :

Company Name: <input type="checkbox"/> Contact person: <input type="checkbox"/> Phone: <input type="checkbox"/> Mobile: <input type="checkbox"/> E-mail: <input type="checkbox"/>	Date Request: <input type="checkbox"/> STA Ref: <input type="checkbox"/>
---	---

Hub Services

Hub Services requested	Yes/no	Start Date (*) (dd/mm/yyyy)
Zeebrugge Beach Physical Trading Services		
ZTP Notional Trading Services		
ZTPL Notional Trading Services		

(*) The services are subscribed for an unlimited duration, as of Start Date

1.13 G.1m – Services Request Form for Capacity Conversion Service



Fluxys Belgium SA - Commercial Direction
 Avenue des Arts 31 - B-1040 Brussels
 Phone: +32 (0)2 282 77 77 - Fax +32 (0)2 282 02 50
info.transport@fluxys.com

G.1m - Service Request Form for Capacity Conversion Service

GRID USER :

Company Name: <input type="text"/>	Date Request: <input type="text"/>
Contact person: <input type="text"/>	STA Ref: <input type="text"/>
Phone: <input type="text"/>	
Mobile: <input type="text"/>	
E-mail: <input type="text"/>	

Case 1 - Conversion Unbundled Capacity at Fluxys Belgium's side

BOOKED IP		REFERENCE Booked Services (AUC-0000000 or SRV-000000)	SERVICE PERIOD*		Converted Quantity (kWh/h)
			Start date	End date	
Dir.	IP		(dd/mm/yyyy)		
New Bundled Capacity contract details (Entry, Exit)					
				
Existing Unbundled Capacity contract details (Entry, Exit, OCUC or Wheeling)					
				

* Must be equal to the standard product (Yearly, Quarterly or Monthly) as acquired on PRISMA

Case 2 - Conversion of Unbundled Capacity at Adjacent TSO's side

BOOKED IP		REFERENCE Booked Services	SERVICE PERIOD		Converted Quantity (kWh/h)
			Start date	End date	
Dir.	IP		(dd/mm/yyyy)		
Existing Unbundled Capacity contract details at the Adjacent TSO**					
				
Unbundled Capacity contract details at Fluxys Belgium's side (Entry, Exit, OCUC or Wheeling)**					
				

** Fluxys Belgium is not responsible for checking the correctness of this information

*** To be filled with Fluxys Belgium's reference to convert existing unbundled Services.
 Left blank to convert with additional capacity – subject to availability

G.2. Services Confirmation Form



The data contained in this document is the property of Fluxys and shall be used for the purposes of the Regulated Transmission Agreement and shall be subject to all provisions of the Regulated Transmission Agreement.
Please note that the information with regard to the tariff in this document is indicative and subject to the currently applicable Regulated Tariff. It is complete as of the date it is available on www.fluxys.com/belgium.

Service Confirmation Form	
CRIC USER	
STANDARD TRANSMISSION AGREEMENT	
REFERENCE	
DATE	

Reference	Information Date	Direction	Edges Code	Capacity Type	Rate Type	Service Detail	Quantity (MWh/yr)	Price (€/MWh)

Reference	Information Date	Direction	Edges Code	Capacity Type	Rate Type	Service Detail	Quantity (MWh/yr)	Price (€/MWh)

Reference	Information Date	Direction	Edges Code	Capacity Type	Rate Type	Service Detail	Quantity (MWh/yr)	HP	SD	ODD	DDRE	Price (€/MWh)

Reference	Information Date	Direction	Edges Code	Capacity Type	Rate Type	Service Detail	Quantity (MWh/yr)	Price (€/MWh)

Reference	Information Date	Direction	Edges Code	Capacity Type	Rate Type	Service Detail	Quantity (MWh/yr)	Price (€/MWh)

Reference	Information Date	Direction	Edges Code	Capacity Type	Rate Type	Service Detail	Quantity (MWh/yr)	Price (€/MWh)

Reference	Information Date	Direction	Edges Code	Capacity Type	Rate Type	Service Detail	Quantity (MWh/yr)	Price (€/MWh)

Reference	Information Date	Direction	Capacity Type	Rate Type	Service Detail	Quantity (MWh/yr)
	Cross Border Delivery Service DSR	Entry	Flow	Yearly		

HUB SERVICES

Hub Services Fee & Regulated Tariff
(published on www.fluxys.com/belgium)

HUB SERVICES	Start Date

Grid4w, duly represented by

Date: _____
 Name: _____
 Position: _____
 Signature: _____

Date: _____
 Name: _____
 Position: _____
 Signature: _____

Fluxys Belgium SA, duly represented by

Date: _____
 Name: _____
 Position: _____
 Signature: _____

Date: _____
 Name: _____
 Position: _____
 Signature: _____

G.3. Assignment Form



Fluxys Belgium SA - Commercial Direction
 Avenue des Arts 31 - B-1040 Brussels
 Phone: +32 (0)2 282 77 77 - Fax +32 (0)2 282 02 50
info.transport@fluxys.com

G.3 - Assignment Request Form

GRID USER (Assignor)

Company Name:	Date Request:	
Contact person:	STA Ref:	
Phone:	Ref Assignor:	
Mobile:		
E-mail:		

GRID USER (Assignee)

Company Name:	Date Request:	
Contact person:	STA Ref:	
Phone:	Ref Assignee:	
Mobile:		
E-mail:		

Assignment

Type of Assignment	
<input type="checkbox"/>	Full assignment
<input type="checkbox"/>	Assignment with retained payment obligations (*)

(*) It being understood that pursuant to the assignment agreement between the Assignor and the Assignee, the payment obligations in respect of this assignment request shall remain with the Assignor, except for the payments with regard to the commodity fee.

TYPE SERVICES	NAME SERVICES	CAPACITY TYPE	RATE TYPE	Quantity (kWh/h)	Price	Start date	End date
						(dd/mm/yyyy)	

G.4. Allocation Agreement

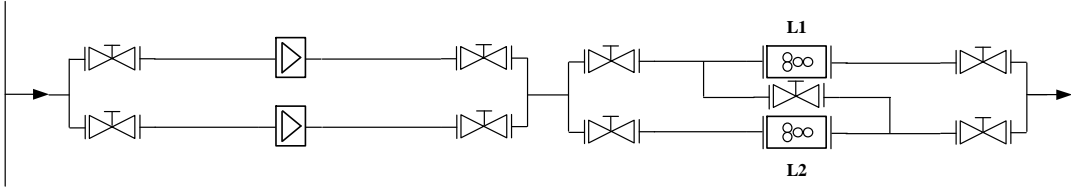
ALLOCATION AGREEMENT		
Supply Point : XXXX		Period: xx/xx/xxxx – xx/xx/xxxx
		
<p><i>The aggregated offtakes at lines L1 and L2 will be allocated at 100 % to the Grid User YYYYYY</i></p>		
<u>For Grid User: YYYYYY</u>	<u>For Transporter</u>	<u>For End Consumer</u>
Date:	Date:	Date:
Name:	Name:	Name:

2

G.5. Form of Capacity Pooling Agreement

<p>Capacity Pooling Agreement Nr [●] Between [●] [●] [●] [TO BE COMPLETED WITH MORE PARTIES IF NEED BE]</p>

This Capacity Pooling Agreement (the “**Capacity Pooling Agreement**”) is made between:

(1)**FLUXYS BELGIUM NV/SA**, a company incorporated in Belgium, having its registered office at Avenue des Arts 31, 1040 Brussels, Belgium, registered at the Register for Legal Entities (RPR/RPM) under number 0402.954.628;

hereinafter referred to as “**the TSO**”;

AND:

(2)[**COMPANY 1**], a company incorporated in [COUNTRY/STATE], having its registered office at [ADDRESS], registered with the [COMPANY REGISTER] under number [NUMBER];
hereinafter referred to as “[●]”;

AND:

(3)[**COMPANY 2**], a company incorporated in [COUNTRY/STATE], having its registered office at [ADDRESS], registered with the [COMPANY REGISTER] under number [NUMBER];
hereinafter referred to as “[●]”;

AND:

(4)[**COMPANY 3**], a company incorporated in [COUNTRY/STATE], having its registered office at [ADDRESS], registered with the [COMPANY REGISTER] under number [NUMBER];
hereinafter referred to as “[●]”.

To the above parties may hereinafter be collectively referred to as the “**Parties**” and individually as a “**Party**”.

WHEREAS:

(A) [●], [●], [●] and [●] have each executed a Standard Transmission Agreement (STA) with the TSO.

(B) The Parties wish to pool the capacities they have subscribed to under their Standard Transmission Agreements in respect of certain End User Domestic Exit Point, subject to and in accordance with the terms and conditions of this Capacity Pooling Agreement.

IN CONSIDERATION OF WHICH IT HAS BEEN AGREED THAT:

1. DEFINITIONS

Unless the context requires otherwise, capitalised terms in this Attachment G shall either have the meaning assigned to them in the Standard Transmission Agreement or shall have the following meaning:

“Capacity Pooling Fee” shall mean the fees due to the TSO by the Parties to this Agreement, other than the TSO for the services provided by the TSO under this Agreement, in accordance with Article 3 of this Capacity Pooling Agreement.

“Capacity Responsible Grid User” or **“CRGU”** shall mean, for a given End User Domestic Exit Point, the Party that assumes the role described under Article 2.3 of this Capacity Pooling Agreement.

“End Date” shall mean the date defined as such in Appendix 1 of this Capacity Pooling Agreement.

“Priority Allocated Grid User” or **“PAGU”** shall mean, for a given End User Domestic Exit Point, the Party that assumes the role described under Article 2.3 of this Capacity Pooling Agreement.

“Start Date” shall mean the date defined as such in Appendix 1 of this Capacity Pooling Agreement.

2. CAPACITY POOLING

2.1 This Capacity Pooling Agreement shall neither alter nor amend the terms and conditions of the STA, which shall remain fully applicable between their respective Parties.

- 2.2 For the purpose of this Capacity Pooling Agreement, Appendix 1 to this Capacity Pooling Agreement lists the respective roles and ranks each Party shall assume in respect of the listed End User Domestic Exit Points.
- 2.3 Subject to the conclusion of an Allocation Agreement and/or an amendment of an existing Allocation Agreement in respect of the End User Domestic Exit Point(s) listed in Appendix 1 to this Capacity Pooling Agreement, and subject to such Allocation Agreement remaining in full force during the entire term of this Capacity Pooling Agreement, it is agreed that for the End User Domestic Exit Point(s) listed in Appendix 1 to this Capacity Pooling Agreement, as from the Start Date until the End Date:
- (i) in accordance with the terms of this Capacity Pooling Agreement:
 - (a) the CRGU shall authorise the PAGU(s) to use all the MTSR subscribed by the CRGU on the relevant End User Domestic Exit Point(s); and,
 - (b) any PAGU shall authorise the CRGU and the other PAGU(s) , if any, to use all the MTSR subscribed by such PAGU on the relevant End User Domestic Exit Points, if any;
 - (ii) the PAGU(s) and the CRGU shall send Nominations in respect of a End User Domestic Exit Point and, if applicable, renominations to The TSO, according to the Operating Procedures of the ACT. It is not allowed that at a given hour, for a given End User Domestic Exit Point, the sum of the energy flow rates exceeds the sum of the Available MTSR for the CRGU and the PAGU(s) at this End User Domestic Exit Point. In case of such an exceeding the TSO shall have the right to first cap the last received Nomination of the CRGU, subsequently the last received Nomination of the PAGU(s) in decreasing rank order so that the sum of the CRGU and PAGU(s) Nominations' shall not exceed the sum of the available MTSR for the CRGU and PAGU(s) at this End User Domestic Exit Point;
 - (iii) the CRGU and the PAGU(s) shall inform each other of their subscribed levels of MTSR at the End User Domestic Exit Point at the time of the Start Date of this Agreement and shall inform each other immediately of any changes of such level of MTSR during the entire period between the Start and End Date of this Agreement;
 - (iv) in case the sum of Exit Energy Allocations of the CRGU and the PAGU(s) exceeds the sum of Available MTSR of the CRGU and the PAGU(s) at a End User Domestic Exit Point, the Exit Energy Incentives, which shall then be calculated based on the sum of the Exit

Energy Allocation of the CRGU and the PAGU(s) at this End User Domestic Exit Point, shall be due by the CRGU;

- (v) notwithstanding the above, the CRGU and the PAGU(s) shall be liable vis-à-vis the TSO for the Incentive for Initial Exit Scheduling and Incentive for Last Exit Scheduling when applicable;
- (vi) note that in case the Fix/Flex Rate Type is attributed on an End User Domestic Exit Point with an active Capacity Pooling Agreement, the CRGU will be responsible for the payment of the flex component based on the Running Hours of the whole End User Domestic Exit Point and therefore will receive access to the final Allocations of the individual PAGU(s); and,
- (vii) the CRGU and the PAGU(s) are severally and jointly liable vis-à-vis the TSO in respect of the terms and conditions of this Capacity Pooling Agreement.

3. CAPACITY POOLING FEE

3.1 General

As from the Start Date, a Capacity Pooling Fee, expressed in Euros, shall be calculated and invoiced monthly by the TSO to each Party other than the TSO, according to the Regulated Tariffs as applicable from time to time.

3.2 Taxes

The Capacity Pooling Fee due under Article 3.1 is exclusive of any taxes, duties or levies of a similar nature. The TSO is entitled to add to the amounts due all taxes, duties or levies of a similar nature imposed on the TSO by any competent authority with respect to or affecting the services provided by the TSO under this Capacity Pooling Agreement (including but not limited to VAT, the levies of the CREG, excise or any taxes or levies whatsoever imposed by public authorities, but excluding taxes on income, profit and share capital).

4. TERM

This Capacity Pooling Agreement shall enter into force as from its execution by all Parties.

5. MISCELLANEOUS

Articles 6 (Invoicing and payment), 10 (Liability), 11 (Force Majeure), 18 (Changed Circumstances) and 20 (Disputes) of the STA, shall be applicable between the TSO and the other Parties in respect of their rights and obligations under this Capacity Pooling Agreement, but not between the Parties other than the TSO.

* * *

For The TSO:	
Name:	Name:
Title:	Title:
Date:	Date:

For : [COMPANY 1]	
Name:	Name:
Title:	Title:
Date:	Date:
For : [COMPANY 2]	
Name:	Name:
Title:	Title:
Date:	Date:
For : [COMPANY 3]	
Name:	Name:
Title:	Title:
Date:	Date:

APPENDIX 1: Allocation Agreement for Capacity Pooling @ End User Domestic Exit Point Service

ALLOCATION AGREEMENT	
End User Domestic Exit Point: [XXX] GEL N°: [YYY] Node: [ZZZ]	Grid Users: CRGU: [●] PAGU with rank1: [●] PAGU with rank2: [●] PAGU with rankn: [●]
Period : Start Date: [dd/mm/yyyy]	End Date: [dd/mm/yyyy]

[Picture of the End User End User Domestic Exit Point]

1. Priority Allocated Grid User rank 1:

If the aggregated hourly offtakes at lines [Relevant Lines of Node ZZZ] are higher than the confirmed nominated quantity of PAGU with rank 1 for the relevant hour, the hourly allocation to PAGU with rank 1 will be equal to the nominated quantity of PAGU with rank 1 for the relevant hour.

If the aggregated hourly offtakes at lines [Relevant Lines of Node ZZZ] are equal or below the confirmed nominated quantity of PAGU with rank 1 for the relevant hour, the hourly allocation to PAGU with rank 1 will be equal to the aggregated hourly offtakes at lines [Relevant Lines of Node ZZZ] for the relevant hour.

2. Priority Allocated Grid User rank n:

If the aggregated hourly offtakes at lines [Relevant Lines of Node ZZZ] are higher than the sum of the confirmed nominated quantities of PAGU with rank 1...n-1 for the relevant hour, the hourly allocation to PAGU with rank n will be equal to the minimum of the nominated quantity of PAGU with rank n and the difference between the aggregated hourly offtakes at lines [Relevant Lines of Node ZZZ] and the sum of the confirmed nominated quantities of PAGU with rank 1...n-1 for the relevant hour.

If the aggregated hourly offtakes at lines [Relevant Lines of Node ZZZ] are lower than the sum of the confirmed nominated quantities of PAGU with rank 1...n-1, the hourly allocation to PAGU with rank n will be equal to zero.

3. Saldo - Capacity Responsible Grid User:

If the aggregated hourly offtakes at lines [Relevant Lines of Node ZZZ] are higher than the sum of the confirmed nominated quantity of PAGU(s) for the relevant hour, the hourly allocation to CRGU will be equal to the difference between the aggregated

hourly offtakes at lines [Relevant Lines of Node ZZZ] and the sum of the nominated quantity of PAGU(s) for the relevant hour.

If the aggregated hourly offtakes at lines [Relevant Lines of Node ZZZ] are equal or below the sum of the confirmed nominated quantity of PAGU(s) for the relevant hour, the hourly allocation to CRGU will be equal to 0.

For CRGU: [COMPANY 1]	
Name: Title Date:	Name: Title: Date:
For PAGU with rank 1 : [COMPANY 2]	
Name: Title Date:	Name: Title: Date:
For PAGU with rank 2 : [COMPANY 3]	
Name: Title Date:	Name: Title: Date:
For PAGU with rank n : [COMPANY 4]	
Name: Title Date:	Name: Title: Date:

For The TSO:	
Name: Title: Date:	Name: Title: Date:

For End Consumer:	
Name: Title: Date:	Name: Title: Date:

G.6 Grid User Details Form

COMPANY

- ◆ Company name:
- ◆ Address:

- ◆ Phone number:
- ◆ Fax number:
- ◆ The company is incorporated
under the laws of:
- ◆ Registered office:
- ◆ Chamber of commerce:
- ◆ City and Registration number:
- ◆ Legally representatives (signature of the STA):
 1. Name:
Function:

 2. Name:
Function:

- ◆ EAN Number¹:

CONTACTS

Commercial contact:

- ◆ Contact name:
- ◆ Function:
- ◆ Address:

- ◆ Phone number:
- ◆ Fax number:
- ◆ Mobile:
- ◆ Email address:
- ◆ Dedicated Email address (Department or Team):

¹ In case of your company will be active on Distribution Domestic Exit Points.

Back-up Commercial Contact:

- ◆ Contact name:
- ◆ Function:
- ◆ Address:

- ◆ Phone number:
- ◆ Fax number:
- ◆ Mobile:
- ◆ Email address:

Operational contact:²

- ◆ Contact name:
- ◆ Function:
- ◆ Address:

- ◆ Phone number:
- ◆ Edigas phone number:
- ◆ Fax number:
- ◆ Mobile:
- ◆ Email address:
- ◆ Dedicated Email address (Department or Team):

ICT contact:

- ◆ Contact name:
- ◆ Function:
- ◆ Address:

- ◆ Phone number:
- ◆ Fax number:
- ◆ Mobile:
- ◆ Email address:
- ◆ Dedicated Email address (Department or Team):

² Operational parameters (shipper's code...), communication protocol, ICT maintenance notices...

INVOICING

Main Invoicing

- ◆ Company name:
- ◆ Invoicing contact name:
- ◆ Address:

- ◆ Phone number:
- ◆ Fax number:
- ◆ Mobile:
- ◆ Email address:
- ◆ Bank name:
- ◆ Bank address:

- ◆ Account number:
- ◆ IBAN Code:
- ◆ BIC Code:
- ◆ VAT number:
- ◆ Register for Legal Entities

Invoicing Mailing Address

- ◆ Company name:
- ◆ First Name:
- ◆ Surname:
- ◆ Function:
- ◆ Address:

Subscription to E-Invoicing³

(Allows downloading electronic invoices from the Electronic Data Platform (EDP))

- ◆ Email address to receive notification of publication:

Purchase status:

- ◆ Taxable Dealer⁴ or End Consumer

³ If not filled out, paper invoice will remain to be sent by post.

⁴ For purpose of VAT, a "taxable dealer" is defined in the Directive 2003/92/EC as a taxable person whose principal activity in respect of purchases of gas and electricity is reselling such products and whose own consumption of these products is negligible.

G.7 TSO Details Form

COMPANY

- ◆ Company name: FLUXYS BELGIUM S.A.
- ◆ Address: Avenue des Arts 31
1040 BRUSSELS
BELGIUM

- ◆ Phone number:
- ◆ Fax number:
- ◆ The company is incorporated
under the laws of:
- ◆ Registered office:
- ◆ Chamber of commerce:
- ◆ City and Registration number:
- ◆ VAT number:

CONTACTS

Commercial contact:

- ◆ Contact name:
- ◆ Function:
- ◆ Phone number:
- ◆ Fax number:
- ◆ Email address:

Administrative contact:

- ◆ Contact name:
- ◆ Function:
- ◆ Phone number:
- ◆ Fax number:
- ◆ Email address:
- ◆ Dedicated Email address – Commercial Team:

Operational contact:

- ◆ Contact name:
- ◆ Phone number:
- ◆ Edigas phone number:
- ◆ Fax number:
- ◆ Email address:

G.8. Oversubscription and Buy-Back (CMP)

G.8a – Notification of Buy-Back



Fluxys Belgium SA - Commercial Direction
Avenue des Arts 31 - B-1040 Brussels
Phone: +32 (0)2 282 77 77 - Fax +32 (0)2 282 02 50
info.transport@fluxys.com

G.8a - Notification of Buy-Back

From: Fluxys Belgium
To: Grid Users holding Firm Transmission Services

Dear Grid User,

Please be advised that aggregated nominations exceed, or are predicted to exceed, the physical capability of the Interconnection Point [XXX] in the [positive/negative] direction ([Entry/Exit]) on gasday [DD/MM/YYYY] CET as from [DD/MM/YYYY hh:mm] till [DD/MM/YYYY hh:mm] CET included.

As you are a Grid User who is holding Firm Transmission Services on this Interconnection Point in the given direction, you are invited to enter the attached Capacity Buy-Back Offer offering to sell Firm Transmission Services for this period back to Fluxys Belgium.

All Capacity Buy-Back Offers received at the Buy-Back Closure Time [DD/MM/YYYY hh:mm] will be accepted from the lowest bid price limited to the Maximum Buy-Back Price until the required buy-back volume is met.

May we kindly ask you to fill in the attached Capacity Buy-Back Offer and to send it back before the Buy-Back Closure Time to Fluxys Belgium via dispatching@fluxys.com.

Yours sincerely,

G.8b – Capacity Buy-Back Offer



Fluxys Belgium SA - Commercial Direction
Avenue des Arts 31 - B-1040 Brussels
Phone: +32 (0)2 282 77 77 - Fax +32 (0)2 282 02 50
info.transport@fluxys.com

G.8b - Capacity Buy-Back Offer

From: **GRID USER :**

Company Name: Date Request:
Contact person:
Phone: STA Ref:
Mobile:
E-mail:

To: Fluxys Belgium : dispatching@fluxys.com

Dear Fluxys,

After received of the Notification of Buy-Back on the Interconnection [XXX] in the [positive/negative] direction ([Entry/Exit]) on gasday [DD/MM/YYYY] as from [DD/MM/YYYY hh:mm] CET till [DD/MM/YYYY hh:mm] CET, our company is offering to sell the following Firm Transmission Services for this period back to Fluxys Belgium.

Quantity (kWh/h)	Price (ct/kWh/h/Runtime)

Yours sincerely,

G.8c – Result Capacity Buy-Back Offer



Fluxys Belgium SA - Commercial Direction
Avenue des Arts 31 - B-1040 Brussels
Phone: +32 (0)2 282 77 77 - Fax +32 (0)2 282 02 50
info.transport@fluxys.com

G.8c - Result Capacity Buy-Back Offer

From: Fluxys Belgium
To: Grid User [XXX]

Dear Grid User,

Please find in the table hereafter the result of the Capacity Buy-Back Offer you have submitted in order to sell Firm Transmission Services back to Fluxys Belgium

Interconnection Point	As from	Till (Included)	Contract Reference	Quantity (kWh/h)
	DD/MM/YYYY hh:mm	DD/MM/YYYY hh:mm		

Yours sincerely,

G.9 – Surrender of Capacity



Fluxys Belgium SA - Commercial Direction
Avenue des Arts 31 - B-1040 Brussels
Phone: +32 (0)2 282 77 77 - Fax +32 (0)2 282 02 50
info.transport@fluxys.com

G.9 - Surrender Request

From: **GRID USER :**

Company Name:	Date Request:
Contact person:		
Phone:	STA Ref:
Mobile:		
E-mail:		

Dear Fluxys,

Grid User [XXX] is willing to surrender the following Transmission Services to Fluxys Belgium.

As from	Till (Included)	Contract Reference	Quantity (kWh/h)
DD/MM/YYYY	DD/MM/YYYY		

Yours sincerely,

G.10. Imbalance Pooling Form

G.10 - Imbalance Pooling Form					
GRID USER (Transferor)					
Company Name:	Date Request:		
Contact person:	STA Ref:		
Phone:	Ref Transferor		
Mobile:				
E-mail:				
GRID USER (Transferee)					
Company Name:	Date Request:		
Contact person:	STA Ref:		
Phone:	Ref Transferee		
Mobile:				
E-mail:				
Imbalance Pooling Service					
Start Date	dd/mm/yyyy	End Date	dd/mm/yyyy		
Transferor accepts that its hourly Imbalance is transferred to the Grid User Balancing Position of the Transferee as set out in Section 3.10 of Attachment A of the ACT					
Transferee accepts that hourly Imbalance of the Transferee is transferred to its Grid User Balancing Position as set out in Section 3.10 of Attachment A of the ACT					
This Form is made up in (place) on (date) in three original copies (one for each party).					
For and on behalf of the Transferor		For and on behalf of the Transferee		For and on behalf of the Transmission System Operator	
Date:	Date:	Date:
Company:	Company:	Company:	Fluxys Belgium
Name:	Name:	Name:
Function:	Function:	Function:
Signature:	Signature:	Signature:
Date:	Date:	Date:
Name:	Name:	Name:
Function:	Function:	Function:
Signature:	Signature:	Signature:

* * *